

UREI INSTALLATIONS

UREI TIME ALIGN® MONITORS

Since their introduction in the late seventies, UREI Time Align® monitors have provided serious recording studio owners and engineers with a coaxial monitor combining time corrected response over the entire audio band with the capability of high acoustical output. The original Time Align monitors were modified Altec 604 loudspeakers with a dividing network designed by Ed Long Associates. The network corrected the inherent time offset between the high and low frequency elements, thus enabling the combined elements to act nearly as one. The result was a virtual point source of sound capable of repro-

ducing square waves, a difficult job for any loudspeaker.

The idea for the system had come from veteran recording engineer Bill Putnam, the Chief Executive Officer of UREI. In time, Putnam sold UREI to JBL, and the monitor took on new life as UREI engineers, working with JBL transducer engineering, brought the benefits of 100mm (4") voice coils and titanium diaphragms to the basic two-way transducer. The current Time Align models reflect these and other improvements and are able to handle more power than their predecessors with audibly cleaner response.

“We purchased UREI 813C monitors for our film and video post production suite as part of the recent upgrade to a left, center, right monitor system. The reason for the purchase was based primarily on years of quality music product from our studios as a result of using the 813A's, still in use in two rooms.”

Ron Lagerlof,
Studio Manager
Hitsville Studios



Hitsville Studios, Motown Records, Hollywood, CA

Urei

We are pleased to list the following 24-track studios which use large format UREI Time Align monitors. USA listings are taken from recent issues of Mix Magazine through early 1988. United Kingdom listings are from the APRS Studio Guide. Japan listings are from Pro Sound Magazine. We apologize in advance for any errors or omissions.

► **Southern California Studios:**

Airdrome Recording, Los Angeles, CA
 Capitol Records Studios, Hollywood, CA
 Evergreen Recording Studios, Studio City, CA
 Fidelity Studios, Inc., Studio City, CA
 Golden Goose Productions, Costa Mesa, CA
 Goldmine Recording Studio, Ventura, CA
 Hitsville Recording Studios, West Hollywood, CA
 Indian Hill Recording, Claremont, CA
 Metropolis Recorders Inc., Studio City, CA
 Preferred Sound, Woodland Hills, CA
 Recording Services Company, Burbank, CA
 Score One Recording, Inc., North Hollywood, CA
 7th Street Sound, Los Angeles, CA
 Sound Design, Santa Barbara, CA
 George Tobin, North Hollywood, CA
 Total Access Recording, Redondo Beach, CA

► **Northeast Studios:**

Atlantic Recording Studios, New York, NY
 Automated Sound Studios, New York, NY
 Bearsville Studios, Bearsville, NY
 Bit Mo Recording, Wheaton, MD
 Blackbeard Studios, Lincoln, RI
 Blue Jay Recording Studio, Inc., Carlisle, MA
 Celestial Sounds, New York, NY
 Clinton Recording Studios, Inc., New York, NY
 Cove City Sound Studios, Glen Cove, NY
 Downtown Recorders, Boston, MA
 Dreamland Recording Studios, Bearsville, NY
 East Side Sound Co. Inc., New York, NY
 Grog Kill Studio, Woodstock-Willow, NY
 Hillside Sound Studio, Englewood, NJ
 Hit and Run Studios, Rockville, MD
 House of Music, Inc., West Orange, NJ
 "If Walls Could Talk" Studios, Caldwell, NJ
 Intergalactic Music Inc., New York, NY
 Kajem Studios Ltd. USA, Gladwyne, PA
 KCC Audio/Video, New York, NY
 Lion and Fox Recording, Inc., Washington, DC
 Long View Farm, North Brookfield, MA
 Megaphone, Portland, ME
 Mission Control, Boston, MA
 Newbury Sound Inc., Boston, MA
 Normandy Sound, Inc., Warren, RI
 NYU Music Technology Studios, New York, NY

Omega Recording Studios, Rockville, MD
 Peabody Recording Studios, Baltimore, MD
 Planet Audio-Video Recording Studios, New York, NY
 Platinum Factory Inc., Brooklyn, NY
 Power Play Studios, Long Island City, NY
 Premier Recording, Inc., Washington, DC
 Quadrasonic Sound, New York, NY
 Quantun Sound Studios, Jersey City, NJ
 Rockin' Reel Recording, East Northport, NY
 Howard Schwartz Recording, New York, NY
 Shakedown Sound, New York, NY
 Sigma Sound Studios, Inc., Philadelphia, PA
 Skyline Studios, Inc., New York, NY
 Sound Investment Recording Studio, Durea, PA
 Sound on Sound Recording, Inc., New York, NY
 Sound Works Digital Studios, Ltd., New York, NY
 Soundtrack, New York, NY
 Spectrum Recorders, Lanesboro, MA
 Star Mix Studios, Ltd., Massapequa, NY
 Sync Sound, Inc., New York, NY
 Tiki Recording Studios, Inc., Glen Cove, NY
 Unique Recording Studio, New York, NY
 White Crow Audio, Burlington, VT

“Capitol Records selected the UREI 813 monitoring system for Studio C due to the Time Aligned components and inherent frequency response of the system. This gives us good imaging and great results in mastering.”

Jeff Minnich,
 Chief Engineer
 Capitol Records



Capitol Records, Hollywood, CA



University of Southern California, School of Cinema-Television, Spielberg Scoring Stage, Los Angeles, CA

“ The School of Cinema-Television at the University of Southern California chose the UREI Model 813 for its Spielberg Scoring Stage because its widespread use in recording studios makes it an industry standard. Furthermore, its ruggedness meets the requirements of a teaching institution since students do make mistakes; the UREI 813 is very forgiving.”

Herbert Farmer
Associate Dean of
Business Affairs
University of
Southern California
School of
Cinema-Television

► **Southeast Studios:**

Alpha Audio, Richmond, VA
Chandler Audio, Ashland, KY
Commercial Music Recording Complex,
Memphis, TN
Cook Sound Studios, Fort Payne, AL
Crosstown Audio, Atlanta, GA
Cue Recording, Ltd., Falls Church, VA
Doppler Studios, Inc., Atlanta, GA
Great Circle Sound, Nashville, TN
Morrisound Recording, Tampa, FL
New River Studios, Fort Lauderdale, FL
Parc Studios, Orlando, FL
The Terminal, Jackson, MS

► **Northwest Studios:**

CD Studios, San Francisco, CA
Coast Recorders, San Francisco, CA
Colorado Sound Recording,
Westminster, CO
Dragon Studios, Redwood City, CA
FTM Studios, Denver, CO
Steve Lawson Productions, Seattle, WA
Mobius Music Recording,
San Francisco, CA
Montage Recording Studios, Newark, CA
Moon Recording, Sacramento, CA
Music Annex, Inc., Menlo Park, CA
Music Art Recording Studios, Aptos, CA

The Music Source, Seattle, WA
Paradise Studios, Sacramento, CA
Prairie Sun Recording, Cotati, CA
R.O. Studios, Concord, CA
Russian Hill Recording,
San Francisco, CA
Sound Impressions, Milwaukie, OR
Spectrum Sound Studios, Portland, OR
Starlight Sound, Richmond, CA
Staunton Studios, Inc., Medford, OR
Swingstreet Studios, Sacramento, CA
Tarpan Studios, San Rafael, CA

► **Southwest Studios:**

Crystal Clear Sound, Dallas, TX
Dallas Sound Lab, Irving, TX
Future Audio, Dallas, TX
Gravity Recording Studio, Nogales, AZ
The Sound Factory Recording Studios,
Tucson, AZ
Studio Southwest, Sunnyvale, TX

► **North Central Recording Studios:**

The Alliance Recording Company,
Southfield, MI
ARS Recording Studio, Alsip, IL
Barn Burner Studio, North Annawan, IL
Beachwood Studios, Beachwood, OH

Breezeway Recording Studio,
Waukesha, WI
Chicago Recording Company,
Chicago, IL
Chicago Trax Recording, Chicago, IL
Clockwerke Sound Studio, Cleveland, OH
Jor-Dan, Inc., Wheaton, IL
Kopperhead Productions, Inc.,
North Canton, OH
Producers Color Service Inc.,
Southfield, MI
PS Recording Studios, Chicago, IL
The Recording Workshop,
Chillicothe, OH
Refraze Recording Studio, Dayton, OH
Sound Impressions, Inc., Des Plaines, IL
Spectrum Sound Studios,
St. Clair Shores, MI
Streetsville Studios, Chicago, IL
Studio A Recording,
Dearborn Heights, MI
Studiomedia Recording Company,
Evanston, IL
Tone Zone Recording, Chicago, IL
United Recording Studio, Kansas City, KS
Wasson's Studio, Boonville, IN
Zenith/db Studios, Chicago, IL

► **United Kingdom Studios:**

Abbey Road, London
Eel Pie Studios, Twickenham
ICC Studios, Eastbourne
Loco Studios, Gwent
Mayfair Recording Studios, London
Odyssey Recording Studios, London
Powerplant Music and Recording Ltd.,
London
PWL, London
Select Sound Studios, Knebworth
Surrey Sound, Leatherhead
The Smokehouse, London
Wessex Studios, London

► **Japan Studios:**

Chiyoda Kouka Geijutsu Senmon Gakku,
Tokyo
Hitotsubashi Studio, Tokyo
Imagica R Studio, Tokyo
Kurohsu Studio, Tokyo
Laser Disc, Akasaka, Tokyo
Magnet Studio, Tokyo
Mediabam Studio, Tokyo
Omnibus Japan, Tokyo
Recording Studio M, Hiroshima
Sound Atorie, Tokyo
Studio Alta, Tokyo
Studio Birdman, Tokyo
Studio Free 2nd, Tokyo
TDK Video Center, Tokyo
TV Tokyo
TVT Akasaka, Tokyo
Tohoku-Shinsya, Tokyo
Zero Studio, Tokyo

Time Align® is a registered trademark of
E.M. Long Associates.

UREI TIME ALIGN® COAXIAL DRIVER

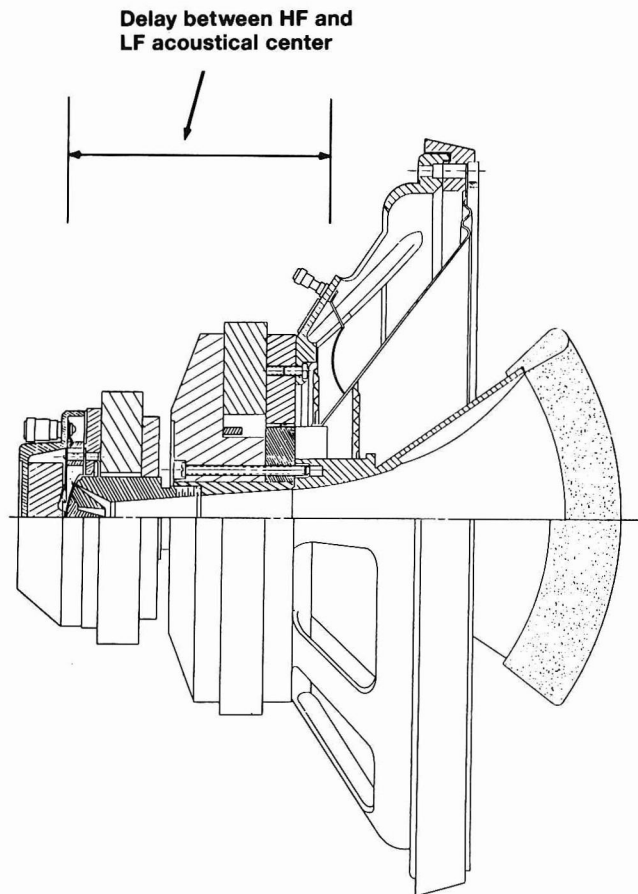

Urei

JBL Incorporated
8500 Balboa Boulevard
Northridge, California 91329, USA

Prestige—UREI Monitors 9/88